

TSK STANDARD/STRONG OPEN SPELTER SOCKET



This socket is lighter and stronger than the general JIS type socket. The wire ropes vary according to the type of sockets, as follows-

The standard type : Strand Rope

The strong type : Spiral Strand Rope, Locked Coil Strand Rope

Material : S35C

Surface Treatment : Self Color or Hot Dip Galvanizing

**TOKYO ROPE MFG.CO.,LTD. developed TSK Spelter Socket.

**We can also manufacture the products by using other materials and applying surface treatment other than the above.



AUZAC CO.,LTD.

26-229, Tomochoushiroji, Fukuyama-shi, Hiroshima, Japan

mail:info@auzac.jp

HP:<https://www.auzac.com/>



TSK OPEN SPELTER SOCKET

STANDARD TYPE

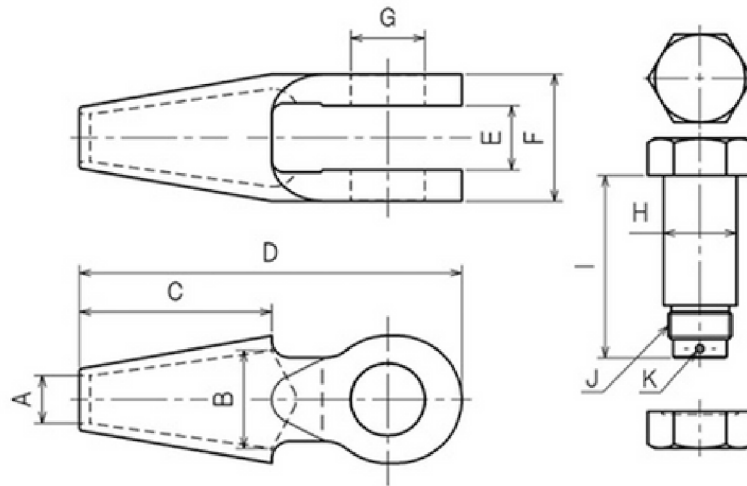

mm dimension

Model Number	M.B.L (Mtons)	for wire Φ (mm)	Dimensions(mm)									weight (kg)	*reference	
			ΦA	ΦB	C	D	E	F	ΦG	ΦH	I		L (metric thread)	S.W.L. (Mtons)
OSS TSK O-16	19.5	16	16	21	40	74	152	26	52	31	30.5	1.47	M27	6.5
OSS TSK O-18	24.7	18	18	23	46	84	172	30	60	35	34.5	2.2	M30	8.2
OSS TSK O-20	30.5	20	20	25	50	92	190	34	66	38	37.5	2.9	M33	10.2
OSS TSK O-22	36.9	22	22	28	56	102	204	36	72	41	40.5	3.7	M36	12.3
OSS TSK O-24	43.9	24	24	30	50	112	224	40	78	45	44.5	4.7	M39	14.6
OSS TSK O-26	51.5	26	26	32	64	122	244	42	84	48	47.5	6	M42	17.2
OSS TSK O-28	59.7	28	28	34	70	132	266	46	90	52	51	7.3	M45	19.9
OSS TSK O-30	68.6	30	30	36	74	140	218	48	96	55	54	8.9	M48	22.9
OSS TSK O-32	78	32	32	39	80	152	300	52	104	59	58	11.1	M52	260
OSS TSK O-34	88.1	34	34	41	84	158	316	56	110	63	62	12.7	M52	29.4
OSS TSK O-36	98.7	36	36	44	88	168	336	58	114	66	65	14.5	M56	32.9
OSS TSK O-38	110	38	38	46	94	176	356	62	122	70	69	17.6	M60	36.7
OSS TSK O-40	122	40	40	48	93	188	370	64	128	73	72	20.5	M64	40.7
OSS TSK O-42	134	42	42	50	102	198	390	68	134	77	76	23	M68	44.7
OSS TSK O-44	147	44	44	52	103	206	405	70	140	80	79	26	M68	49
OSS TSK O-46	161	46	46	54	112	216	430	74	146	84	83	30	M72 x 6	53.7
OSS TSK O-48	176	48	48	56	116	228	445	76	152	87	86	34	M76 x 6	58.7
OSS TSK O-50	190	50	50	59	122	236	465	80	158	90	89	38	M80 x 6	63
OSS TSK O-52	206	52	52	62	128	244	485	84	166	94	93	43	M80 x 6	68.7
OSS TSK O-54	222	54	54	64	132	252	495	86	172	97	96	47	M85 x 6	74
OSS TSK O-56	239	56	56	66	136	254	520	90	173	101	99.5	51	M85 x 6	79.7
OSS TSK O-58	256	58	58	68	142	274	535	92	184	105	103.5	58	M90 x 6	85
OSS TSK O-60	274	60	60	70	146	282	555	96	190	109	107.5	66	M95 x 6	91
OSS TSK O-62	293	62	62	72	150	292	575	98	196	112	110.5	71	M95 x 6	97.7
OSS TSK O-64	312	64	64	74	156	306	595	102	202	116	114.5	78	M100 x 6	104
OSS TSK O-66	332	66	66	77	160	312	610	104	208	119	117.5	86	M105 x 6	111
OSS TSK O-68	352	68	68	79	154	322	635	108	214	123	121.5	93	M105 x 6	117
OSS TSK O-70	373	70	70	81	170	330	645	112	222	127	125.5	102	M110 x 6	124
OSS TSK O-72	395	72	72	83	174	342	670	114	226	130	128.5	113	M115 x 6	132
OSS TSK O-74	417	74	74	85	173	352	690	116	232	133	131.5	119	M115 X 6	139
OSS TSK O-76	440	76	76	87	184	350	700	120	240	137	135.5	132	M120 x 6	147
OSS TSK O-78	464	78	78	89	188	370	720	124	246	140	138.5	139	M120 x 6	155
OSS TSK O-80	488	80	80	92	194	330	740	126	252	144	142.5	152	M125 X 6	163
OSS TSK O-82	512	82	82	94	198	390	760	130	258	147	145.5	164	M130 x 6	171
OSS TSK O-84	538	84	84	96	202	400	780	132	264	150	148.5	173	M130 x 6	179
OSS TSK O-86	563	86	86	98	208	410	800	136	270	154	152.5	189	M135 x 6	188
OSS TSK O-88	590	88	88	100	212	420	820	138	276	157	155.5	200	M135 X 6	197
OSS TSK O-90	617	90	90	102	216	430	840	142	282	161	159.5	214	M140 x 6	206
OSS TSK O-92	645	92	92	104	222	440	850	146	290	165	163.5	234	M145 X 6	215
OSS TSK O-94	673	94	94	101	225	448	870	148	296	168	166.5	246	M145 x 6	224
OSS TSK O-96	702	96	96	109	232	460	890	152	302	172	170.5	261	M150 x 6	234
OSS TSK O-98	732	98	98	111	236	466	910	154	308	175	173.5	281	M155 x 6	244
OSS TSK O-100	762	100	100	113	240	478	930	158	314	179	177.5	292	M155 x 6	254

TSK OPEN SPELTER SOCKET

STANDARD TYPE

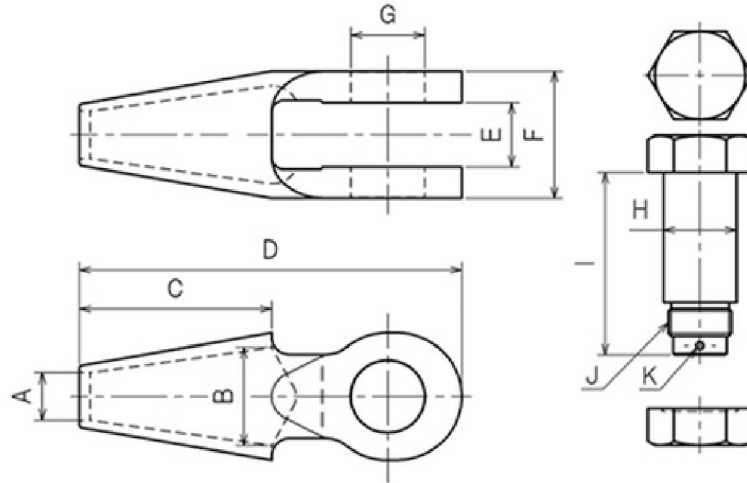

inch dimension

Model Number	M.B.L (Mtons)	for wire Φ (inch)	Dimensions(inch)									weight (kg)	*reference	
			ΦA	ΦB	C	D	E	F	ΦG	ΦH	I		L (metric thread)	S.W.L. (Mtons)
OSS TSK O-16	19.5	5/8	0.63	0.83	1.57	2.91	5.98	1.02	2.05	1.22	1.2	1.47	M27	6.5
OSS TSK O-18	24.7	11/16 - 3/4	0.71	0.91	1.81	3.31	6.77	1.18	2.36	1.38	1.36	2.2	M30	8.2
OSS TSK O-20	30.5	13/16	0.79	0.98	1.97	3.62	7.48	1.34	2.6	1.5	1.48	2.9	M33	10.2
OSS TSK O-22	36.9	7/8	0.87	1.1	2.2	4.02	8.03	1.42	2.83	1.61	1.59	3.7	M36	12.3
OSS TSK O-24	43.9	15/16	0.94	1.18	1.97	4.41	8.82	1.57	3.07	1.77	1.75	4.7	M39	14.6
OSS TSK O-26	51.5	1 - 1 1/16	1.02	1.26	2.52	4.8	9.61	1.65	3.31	1.89	1.87	6	M42	17.2
OSS TSK O-28	59.7	1 1/8	1.1	1.34	2.76	5.2	10.47	1.81	3.54	2.05	2.01	7.3	M45	19.9
OSS TSK O-30	68.6	1 3/16	1.18	1.42	2.91	5.51	8.58	1.89	3.78	2.17	2.13	8.9	M48	22.9
OSS TSK O-32	78	1 1/4	1.26	1.54	3.15	5.98	11.81	2.05	4.09	2.32	2.28	11.1	M52	260
OSS TSK O-34	88.1	1 5/16	1.34	1.61	1.34	6.22	12.44	2.2	4.33	2.48	2.44	12.7	M52	29.4
OSS TSK O-36	98.7	1 1/8 - 1 7/16	1.42	1.73	1.5	6.61	13.23	2.28	43.86	2.6	2.56	14.5	M56	32.9
OSS TSK O-38	110	1 7/16 - 1 1/2	1.5	1.81	3.7	6.93	14.02	2.44	4.8	2.76	2.72	17.6	M60	36.7
OSS TSK O-40	122	1 9/16	1.57	1.89	3.66	7.4	14.57	2.52	5.04	2.87	2.83	20.5	M64	40.7
OSS TSK O-42	134	1 11/16	1.65	1.97	4.02	7.8	15.35	2.68	5.28	3.03	2.99	23	M68	44.7
OSS TSK O-44	147	1 3/4	1.73	2.05	4.06	8.11	15.94	2.76	5.51	3.15	3.11	26	M68	49
OSS TSK O-46	161	1 13/16	1.81	2.13	4.41	8.5	16.93	2.91	5.75	3.31	3.27	30	M72 x 6	53.7
OSS TSK O-48	176	1 7/8	1.89	2.2	4.57	8.98	17.52	2.99	5.98	3.43	3.39	34	M76 x 6	58.7
OSS TSK O-50	190	1 15/16 - 2	1.97	2.32	4.8	9.29	18.31	3.15	6.22	3.54	3.5	38	M80 x 6	63
OSS TSK O-52	206	2 1/16	2.05	2.44	5.04	9.61	19.09	3.31	6.54	3.7	3.66	43	M80 x 6	68.7
OSS TSK O-54	222	2 1/8	2.13	2.52	5.2	9.92	19.49	3.39	6.77	3.82	3.78	47	M85 x 6	74
OSS TSK O-56	239	2 3/16	2.2	2.6	5.35	10	20.47	3.54	6.81	3.98	3.92	51	M85 x 6	79.7
OSS TSK O-58	256	2 1/4 - 2 5/16	2.28	2.68	5.59	10.79	21.06	3.62	7.24	4.13	4.07	58	M90 x 6	85
OSS TSK O-60	274	2 2/8	2.36	2.76	5.75	11.1	21.85	3.78	7.48	4.29	4.23	66	M95 x 6	91
OSS TSK O-62	293	2 7/16	2.44	2.83	5.91	11.5	22.64	3.86	7.72	4.41	4.35	71	M95 x 6	97.7
OSS TSK O-64	312	2 1/2	2.52	2.91	6.14	12.05	23.43	4.02	7.95	4.57	4.51	78	M100 x 6	104
OSS TSK O-66	332	2 5/8	2.6	3.03	6.3	12.28	24.02	4.09	8.19	4.69	4.63	86	M105 x 6	111
OSS TSK O-68	352	2 11/16	2.68	3.11	6.06	12.68	25	4.25	8.43	4.84	4.78	93	M105 x 6	117
OSS TSK O-70	373	2 3/4	2.76	3.19	6.69	12.99	25.39	4.41	8.74	5	4.94	102	M110 x 6	124
OSS TSK O-72	395	2 13/16 - 2 7/8	2.83	1.3	6.85	13.46	26.38	4.49	8.9	5.12	5.06	113	M115 x 6	132
OSS TSK O-74	417	2 15/16	2.91	3.35	6.81	13.86	27.17	4.57	9.13	5.24	5.18	119	M115 X 6	139
OSS TSK O-76	440	3	2.99	3.43	7.24	13.78	27.56	4.72	9.45	5.39	5.33	132	M120 x 6	147
OSS TSK O-78	464	3 1/16	3.07	1.54	7.4	14.57	28.35	4.88	9.69	5.51	5.45	139	M120 x 6	155
OSS TSK O-80	488	3 3/16	3.15	3.62	7.64	12.99	29.13	4.96	9.92	5.67	5.61	152	M125 X 6	163
OSS TSK O-82	512	3 1/4	3.23	3.7	7.8	15.35	29.92	5.12	10.16	5.79	5.73	164	M130 x 6	171
OSS TSK O-84	538	3 5/16	3.31	3.78	7.95	15.75	30.71	5.2	10.39	5.91	5.85	173	M130 x 6	179
OSS TSK O-86	563	3 3/8	3.39	3.86	8.19	16.14	31.5	5.35	10.63	6.06	6	189	M135 x 6	188
OSS TSK O-88	590	3 7/16 - 3 1/2	3.46	3.94	8.35	16.54	32.28	5.43	10.87	6.18	6.12	200	M135 X 6	197
OSS TSK O-90	617	3 9/16	3.54	4.02	8.5	16.93	33.07	5.59	11.1	6.34	6.28	214	M140 x 6	206
OSS TSK O-92	645	3 5/8	3.62	4.09	8.74	17.32	33.46	5.75	11.42	6.5	6.44	234	M145 X 6	215
OSS TSK O-94	673	3 11/16	3.7	3.98	8.86	17.64	34.25	5.83	11.65	6.61	6.56	246	M145 x 6	224
OSS TSK O-96	702	3 3/4 - 3 13/16	3.78	4.29	9.13	18.11	35.04	5.98	11.89	6.77	6.71	261	M150 x 6	234
OSS TSK O-98	732	3 7/8	3.86	4.37	9.29	18.35	35.83	6.06	12.13	6.89	6.83	281	M155 x 6	244
OSS TSK O-100	762	3 15/16	3.94	4.45	9.45	18.82	36.61	6.22	12.36	7.05	6.99	292	M155 x 6	254

TSK OPEN SPELTER SOCKET

STRONG TYPE

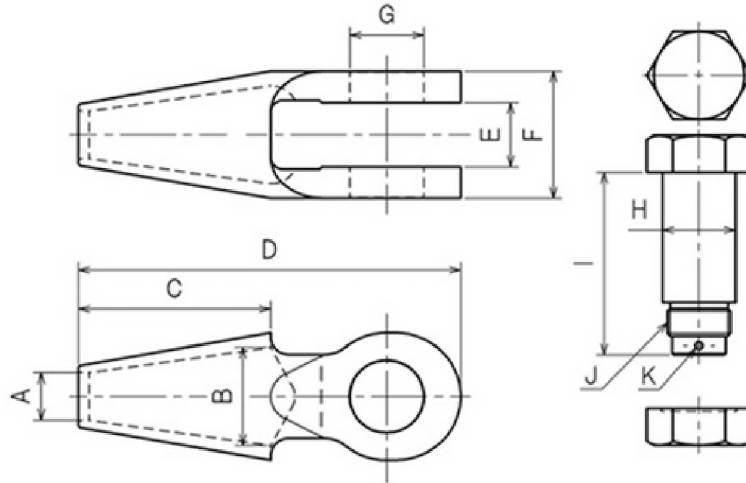

mm dimension

Model Number	M.B.L (Mtons)	for wire Φ (mm)	Dimensions(mm)									weight (kg)	*reference	
			ΦA	ΦB	C	D	E	F	ΦG	ΦH	I		L (metric thread)	S.W.L. (Mtons)
OSS TSKK O-14	-	14	23	44	72	154	28	56	32	31.5	87	1.78	M27 × 2	7.1
OSS TSKK O-16	-	16	24	48	90	182	32	62	37	36.5	97	2.4	M33 × 2	9.3
OSS TSKK O-18	-	18	25	54	104	206	36	70	41	40.5	106	3.4	M36	11.8
OSS TSKK O-20	39.4	20	27	58	114	226	38	76	45	44.5	114	4.6	M39	14.6
OSS TSKK O-22	47.6	22	29	64	126	248	42	84	49	48.5	124	6.1	M42	17.6
OSS TSKK O-24	56.7	24	31	70	142	276	46	92	53	52	134	7.9	M45	21
OSS TSKK O-26	66.5	26	33	74	152	300	50	98	57	56	142	9.6	M48	24.6
OSS TSKK O-28	77.2	28	35	80	164	322	54	106	62	61	156	12.2	M52	28.6
OSS TSKK O-30	88.6	30	38	86	174	342	58	114	66	65	167	15.1	M56	32.8
OSS TSKK O-32	101	32	41	92	188	362	60	120	69	68	175	17.2	M60	37.4
OSS TSKK O-34	114	34	43	96	200	390	64	126	74	73	184	20.7	M64	42.2
OSS TSKK O-36	128	36	45	102	210	410	68	134	78	77	194	24	M68	47.4
OSS TSKK O-38	142	38	47	108	222	432	72	142	82	81	208	28	M72 × 6	52.6
OSS TSKK O-40	157	40	50	114	236	455	76	150	87	86	220	34	M76 × 6	58.2
OSS TSKK O-42	174	42	52	118	248	480	78	156	90	89	228	39	M80 × 6	64.4
OSS TSKK O-44	191	44	54	124	258	500	82	164	94	93	236	43	M80 × 6	70.7
OSS TSKK O-46	208	46	56	130	270	520	86	172	99	98	246	50	M85 × 6	77
OSS TSKK O-48	227	48	58	134	286	550	90	178	104	102.5	256	57	M90 × 6	84.1
OSS TSKK O-50	246	50	60	140	296	570	94	186	108	106.5	273	65	M95 × 6	91.1
OSS TSKK O-52	266	52	64	146	306	590	96	192	112	110.5	279	70	M95 × 6	98.5
OSS TSKK O-54	287	54	66	152	318	615	100	200	116	114.5	290	80	M100 × 6	106
OSS TSKK O-56	309	56	68	158	332	640	104	208	120	118.5	301	90	M105 × 6	114
OSS TSKK O-58	331	58	70	162	344	660	108	214	125	123.5	309	98	M110 × 6	123
OSS TSKK O-60	354	60	72	168	356	680	112	222	129	127.5	317	107	M110 × 6	131
OSS TSKK O-62	378	62	74	174	368	705	116	230	133	131.5	329	121	M115 × 6	140
OSS TSKK O-64	403	64	76	178	382	730	118	236	137	135.5	338	132	M120 × 6	149
OSS TSKK O-66	429	66	78	184	394	750	122	244	141	139.5	350	148	M125 × 6	159
OSS TSKK O-68	455	68	80	190	406	775	126	252	145	143.5	358	159	M125 × 6	169
OSS TSKK O-70	482	70	83	196	416	795	130	260	149	147.5	368	173	M130 × 6	179
OSS TSKK O-72	510	72	85	200	430	825	134	266	154	152.5	383	191	M135 × 6	189
OSS TSKK O-74	539	74	87	206	442	845	136	272	157	155.5	389	200	M135 × 6	200
OSS TSKK O-76	568	76	89	212	454	865	140	280	162	160.5	400	218	M140 × 6	210
OSS TSKK O-78	599	78	91	216	466	895	144	286	166	164.5	409	238	M145 × 6	222
OSS TSKK O-80	630	80	93	222	480	920	148	294	170	168.5	420	259	M150 × 6	233
OSS TSKK O-82	662	82	95	228	490	930	152	302	174	172.5	431	278	M155 × 6	245
OSS TSKK O-84	694	84	97	234	506	960	156	310	179	177.5	439	295	M155 × 6	257
OSS TSKK O-86	728	86	99	238	516	980	158	316	182	180.5	448	316	M160 × 6	270
OSS TSKK O-88	762	88	101	244	528	1000	162	324	186	184.5	459	341	M165 × 6	282
OSS TSKK O-90	797	90	104	250	540	1030	166	332	191	189.5	470	371	M170 × 6	295
OSS TSKK O-92	833	92	106	256	554	1050	170	338	195	193.5	476	385	M170 × 6	309
OSS TSKK O-94	870	94	108	260	564	1070	174	346	199	197.5	487	415	M175 × 6	322
OSS TSKK O-96	907	96	110	266	578	1100	176	352	203	201.5	496	441	M180 × 6	336
OSS TSKK O-98	945	98	112	272	590	1120	180	360	207	205.5	504	464	M180 × 6	350
OSS TSKK O-100	984	100	114	276	602	1140	184	366	211	209.5	521	490	M185 × 6	364

TSK OPEN SPELTER SOCKET

STRONG TYPE

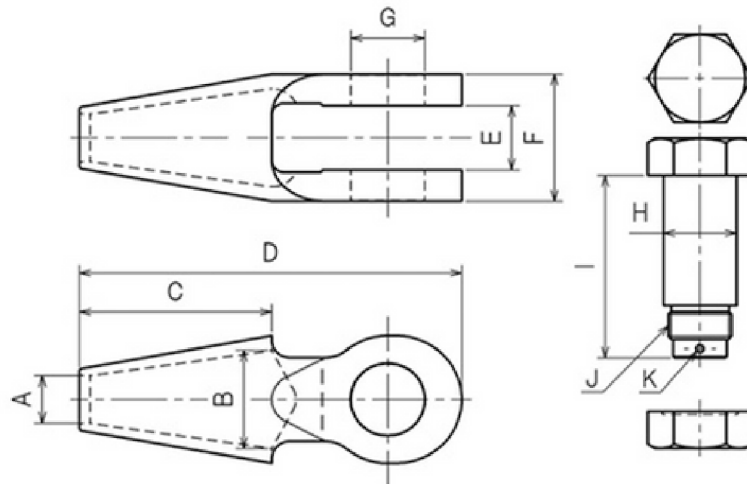

inch dimension

Model Number	M.B.L (Mtons)	for wire Φ (inch)	Dimensions (inch)									weight (kg)	*reference	
			ΦA	ΦB	C	D	E	F	ΦG	ΦH	I		L (metric thread)	S.W.L (Mtons)
OSS TSKK O-14	-	9/16	0.63	0.83	1.57	2.91	5.98	1.02	2.05	1.22	1.2	1.78	M27×2	7.1
OSS TSKK O-16	-	5/8	0.71	0.91	1.81	3.31	6.77	1.18	2.36	1.38	1.36	2.4	M33×2	9.3
OSS TSKK O-18	-	11/16 - 3/4	0.79	0.98	1.97	3.62	7.48	1.34	2.6	1.5	1.48	3.4	M36	11.8
OSS TSKK O-20	39.4	13/16	0.87	1.1	2.2	4.02	8.03	1.42	2.83	1.61	1.59	4.6	M39	14.6
OSS TSKK O-22	47.6	7/8	0.94	1.18	1.97	4.41	8.82	1.57	3.07	1.77	1.75	6.1	M42	17.6
OSS TSKK O-24	56.7	15/16	1.02	1.26	2.52	4.8	9.61	1.65	3.31	1.89	1.87	7.9	M45	21
OSS TSKK O-26	66.5	1 - 1 1/16	1.1	1.34	2.76	5.2	10.47	1.81	3.54	2.05	2.01	9.6	M48	24.6
OSS TSKK O-28	77.2	1 1/8	1.18	1.42	2.91	5.51	8.58	1.89	3.78	2.17	2.13	12.2	M52	28.6
OSS TSKK O-30	88.6	1 3/16	1.26	1.54	3.15	5.98	11.81	2.05	4.09	2.32	2.28	15.1	M56	32.8
OSS TSKK O-32	101	1 1/4	1.34	1.61	3.34	6.22	12.44	2.2	4.33	2.48	2.44	17.2	M60	37.4
OSS TSKK O-34	114	1 5/16	1.42	1.73	3.5	6.61	13.23	2.28	43.86	2.6	2.56	20.7	M64	42.2
OSS TSKK O-36	128	1 7/8 - 1 7/16	1.5	1.81	3.7	6.93	14.02	2.44	4.8	2.76	2.72	24	M68	47.4
OSS TSKK O-38	142	1 7/16 - 1 1/2	1.57	1.89	3.66	7.4	14.57	2.52	5.04	2.87	2.83	28	M72×6	52.6
OSS TSKK O-40	157	1 9/16	1.65	1.97	4.02	7.8	15.35	2.68	5.28	3.03	2.99	34	M76×6	58.2
OSS TSKK O-42	174	1 11/16	1.73	2.05	4.06	8.11	15.94	2.76	5.51	3.15	3.11	39	M80×6	64.4
OSS TSKK O-44	191	1 3/4	1.81	2.13	4.41	8.5	16.93	2.91	5.75	3.31	3.27	43	M80×6	70.7
OSS TSKK O-46	208	1 13/16	1.89	2.2	4.57	8.98	17.52	2.99	5.98	3.43	3.39	50	M85×6	77
OSS TSKK O-48	227	1 7/8	1.97	2.32	4.8	9.29	18.31	3.15	6.22	3.54	3.5	57	M90×6	84.1
OSS TSKK O-50	246	1 15/16 - 2	2.05	2.44	5.04	9.61	19.09	3.31	6.54	3.7	3.66	65	M95×6	91.1
OSS TSKK O-52	266	2 1/16	2.13	2.52	5.2	9.92	19.49	3.39	6.77	3.82	3.78	70	M95×6	98.5
OSS TSKK O-54	287	2 1/8	2.2	2.6	5.35	10	20.47	3.54	6.81	3.98	3.92	80	M100×6	106
OSS TSKK O-56	309	2 3/16	2.28	2.68	5.59	10.79	21.06	3.62	7.24	4.13	4.07	90	M105×6	114
OSS TSKK O-58	331	2 1/4 - 2 5/16	2.36	2.76	5.75	11.1	21.85	3.78	7.48	4.29	4.23	98	M110×6	123
OSS TSKK O-60	354	2 1/4	2.44	2.83	5.91	11.5	22.64	3.86	7.72	4.41	4.35	107	M110×6	131
OSS TSKK O-62	378	2 7/16	2.52	2.91	6.14	12.05	23.43	4.02	7.95	4.57	4.51	121	M115×6	140
OSS TSKK O-64	403	2 1/2	2.6	3.03	6.3	12.28	24.02	4.09	8.19	4.69	4.63	132	M120×6	149
OSS TSKK O-66	429	2 5/8	2.68	3.11	6.06	12.68	25	4.25	8.43	4.84	4.78	148	M125×6	159
OSS TSKK O-68	455	2 11/16	2.76	3.19	6.69	12.99	25.39	4.41	8.74	5	4.94	159	M125×6	169
OSS TSKK O-70	482	2 3/4	2.83	3.3	6.85	13.46	26.38	4.49	8.9	5.12	5.06	173	M130×6	179
OSS TSKK O-72	510	2 13/16 - 2 7/8	2.91	3.35	6.81	13.86	27.17	4.57	9.13	5.24	5.18	191	M135×6	189
OSS TSKK O-74	539	2 15/16	2.99	3.43	7.24	13.78	27.56	4.72	9.45	5.39	5.33	200	M135×6	200
OSS TSKK O-76	568	3	3.07	3.54	7.4	14.57	28.35	4.88	9.69	5.51	5.45	218	M140×6	210
OSS TSKK O-78	599	3 1/16	3.15	3.62	7.64	12.99	29.13	4.96	9.92	5.67	5.61	238	M145×6	222
OSS TSKK O-80	630	3 3/16	3.23	3.7	7.8	15.35	29.92	5.12	10.16	5.79	5.73	259	M150×6	233
OSS TSKK O-82	662	3 1/4	3.31	3.78	7.95	15.75	30.71	5.2	10.39	5.91	5.85	278	M155×6	245
OSS TSKK O-84	694	3 5/16	3.39	3.86	8.19	16.14	31.5	5.35	10.63	6.06	6	295	M155×6	257
OSS TSKK O-86	728	3 3/8	3.46	3.94	8.35	16.54	32.28	5.43	10.87	6.18	6.12	316	M160×6	270
OSS TSKK O-88	762	3 7/16 - 3 1/2	3.54	4.02	8.5	16.93	33.07	5.59	11.1	6.34	6.28	341	M165×6	282
OSS TSKK O-90	797	3 9/16	3.62	4.09	8.74	17.32	33.46	5.75	11.42	6.5	6.44	371	M170×6	295
OSS TSKK O-92	833	3 5/8	3.7	3.98	8.86	17.64	34.25	5.83	11.65	6.61	6.56	385	M170×6	309
OSS TSKK O-94	870	3 11/16	3.78	4.29	9.13	18.11	35.04	5.98	11.89	6.77	6.71	415	M175×6	322
OSS TSKK O-96	907	3 3/4 - 3 13/16	3.86	4.37	9.29	18.35	35.83	6.06	12.13	6.89	6.83	441	M180×6	336
OSS TSKK O-98	945	3 7/8	3.94	4.45	9.45	18.82	36.61	6.22	12.36	7.05	6.99	464	M180×6	350
OSS TSKK O-100	984	3 15/16	3.86	4.37	9.29	18.35	35.83	6.06	12.13	6.89	6.83	490	M185×6	364